

Lesson 17

Objective: Use all four operations to solve problems involving perimeter and missing measurements.

Related Topics: [More Lesson Plans for the Common Core Math](#)

Suggested Lesson Structure

■ Fluency Practice	(12 minutes)
■ Application Problem	(5 minutes)
■ Concept Development	(33 minutes)
■ Student Debrief	(10 minutes)
Total Time	(60 minutes)

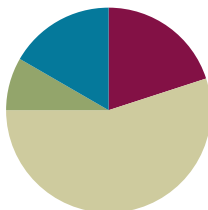

NOTES ON MULTIPLE MEANS OF REPRESENTATION:

If using the Marilyn Burns text and lesson listed below, teach it after today's lesson and before the Mid-Module Assessment. Because it explores the relationship between perimeter and area, the lesson works well as a culmination of G3–M7–Topic C while anticipating G3–M7–Topic D, which incorporates area.

Burns, Marilyn. *Spaghetti and Meatballs for All! A Mathematical Story*. New York: Scholastic Press, 1997.

Fluency Practice (12 minutes)

- Factors **3.MD.4** (4 minutes)
- Equivalent Counting with Units of 8 **3.OA.7** (4 minutes)
- Find the Perimeter **3.MD.8** (4 minutes)

Factors (4 minutes)

Materials: (S) Personal white boards

Note: This activity builds fluency with multiplication and division facts.

T: (Write $8 \times \underline{\quad} = 8$.) Say the equation filling in the missing factor.

S: $8 \times 1 = 8$.

T: (Write $2 \times \underline{\quad} = 8$.) Say the equation filling in the missing factor.

S: $2 \times 4 = 8$.

T: (Write $\underline{\quad} \times 2 = 8$.) Write the equation filling in the missing factor.

S: (Write $4 \times 2 = 8$.)

Continue the process for factors of 12, 15, and 24.

Equivalent Counting with Units of 8 (4 minutes)

Note: This activity builds fluency with multiplication facts using units of 8.

T: Count by eights to 80. (Write as students count.)

S: 8, 16, 24, 32, 40, 48, 56, 64, 72, 80.

T: (Write 1 eight beneath the 8.) Count to 10 eights. (Write as students count.)

8	16	24	32	40	48	56	64	72	80
1 eight	2 eights	3 eights	4 eights	5 eights	6 eights	7 eights	8 eights	9 eights	10 eights

- S: 1 eight, 2 eights, 3 eights, 4 eights, 5 eights, 6 eights, 7 eights, 8 eights, 9 eights, 10 eights.
 T: Let's count to 10 eights again. This time, stop when I raise my hand.
 S: 1 eight, 2 eights, 3 eights.
 T: (Raise hand.) Say the multiplication sentence.
 S: $3 \times 8 = 24$.
 T: Continue.
 S: 4 eights, 5 eights.
 T: (Raise hand.) Say the multiplication sentence.
 S: $5 \times 8 = 40$.
 T: Continue.
 S: 6 eights, 7 eights, 8 eights.
 T: (Raise hand.) Say the multiplication sentence.
 S: $8 \times 8 = 64$.
 T: Continue.
 S: 9 eights, 10 eights.
 T: (Raise hand.) Say the multiplication sentence.
 S: $10 \times 8 = 80$.
 T: Let's count back down, starting at 10 eights.
 S: 10 eights, 9 eights.
 T: (Raise hand.) Say the multiplication sentence.
 S: $9 \times 8 = 72$. Continue the process going back down to 0 eights or 1 eight.

Find the Perimeter (4 minutes)

Materials: (S) Personal white boards

Note: This fluency activity reviews G3–M7–Lesson 15.

- T: (Project triangle with a given length of 4 cm. Write $P = \underline{\hspace{1cm}}$ in.) Each shape that I show you is a regular polygon. Say the given length of the triangle.
 S: 4 centimeters.
 T: (Write $P = \underline{\hspace{1cm}} \times \underline{\hspace{1cm}}$ cm.) Fill in the factors. Below, write the perimeter of the triangle.
 S: (Write $P = 3 \times 4$ cm. Below it, write $P = 12$ cm.)

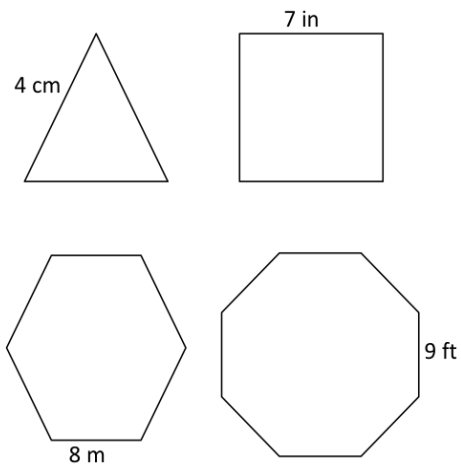

Repeat the process for the other shapes.

Application Problem (5 minutes)

Gil places two regular hexagons side by side as shown to make a new shape. Each side measures 6 centimeters. Find the perimeter of his new shape.

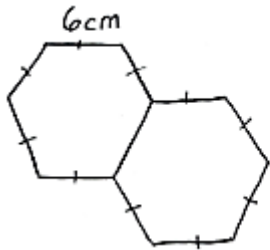

There are 10 sides
in Gil's new shape.
 $10 \times 6 = 60$
The perimeter of
the shape is 60 cm.

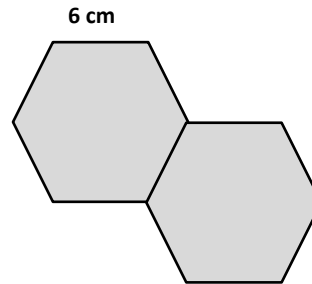

Note: The Application Problem reviews finding the perimeter of regular shapes from G3–M7–Lesson 15. Students may also choose to represent their equation as repeated addition.

Concept Development (33 minutes)

Materials: (S) Personal white boards

T: (Project the image at right.) Can you visualize the rectangles that make up this shape? Tell your partner about them.

S: I see one long one that goes from the top all the way to the bottom, then a smaller one stuck on the bottom right. → I see a long skinny one across the bottom, and a thicker one on top of it to the left.

T: Let's find the perimeter of the shape. Say the side length as I point to it. (Point to the labeled side lengths. Students say them.)

T: (Point to the shorter, unknown side length.)

S: That side length isn't labeled!

T: (Write a cm next to it.) Let's call this side length a cm.

T: (Point to the longer, unknown side length.)

S: That one isn't labeled either!

T: (Write b cm next to it.) Let's call this side length b cm.

T: Think back to how you visualized rectangles fitting together to make this shape. (Draw dashed line as shown.) This is one way to visualize the rectangles. How does the line help you

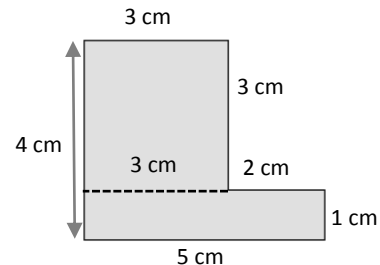
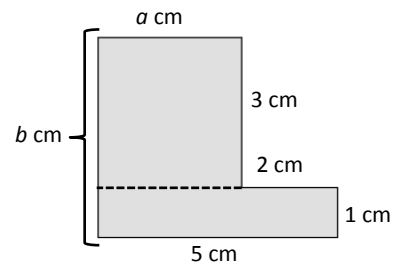
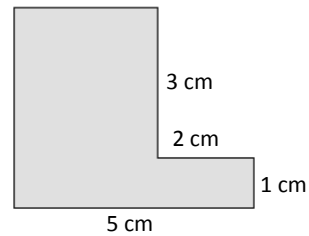

MP.3

find the missing side lengths?

S: Now we can see two rectangles. → We can use what we know about rectangles and the given side lengths to find the missing side lengths. → Yeah, we know that opposite side lengths are equal, which will help us find the missing side lengths.

T: Work with a partner. Use the bottom rectangle to find the length of the dashed line.

S: If the whole bottom is 5 centimeters, then we have to subtract the 2 centimeters that are on the side. $5\text{ cm} - 2\text{ cm} = 3\text{ cm}$. The dashed line is 3 centimeters.

T: (Label length of the dashed line.) How does this help us find the value of a ?

S: The dashed line is the side opposite of a , so a is 3 too!

T: (Label 3 cm for a .) Look at the side lengths for the top rectangle. We know that three side lengths are 3 centimeters. What does that tell us about the fourth side length?

S: It has to be 3 centimeters too! → It's a square!

T: Does that mean that b is 3 too?

S: No! → We have to add on the side length from the bottom rectangle to find the total length of b .

T: Work with a partner to find the total length of b . (Allow students time to work.) What is the length of b ?

S: 4 centimeters!

T: (Label 4 cm for b and draw arrow as shown.) I drew an arrow to show that the length of this entire side is 4 centimeters. Write a number sentence, including units, that shows the perimeter of this shape.

S: $5\text{ cm} + 1\text{ cm} + 2\text{ cm} + 3\text{ cm} + 3\text{ cm} + 4\text{ cm} = 18\text{ cm}$. → $(3 \times 3\text{ cm}) + 4\text{ cm} + 5\text{ cm} = 18\text{ cm}$.

T: What is the perimeter of the shape?

S: 18 centimeters!

T: (Erase dashed line and draw new dashed line as shown.) Discuss with a partner how you would solve by visualizing the rectangles this way instead.

S: (Discuss.)

Continue with the following possible shapes.

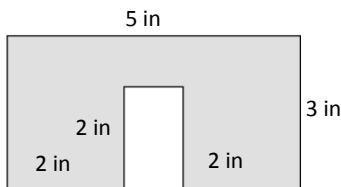

Possible solution path: Draw a dotted line connecting the 2-inch sides to make one large rectangle, as shown.

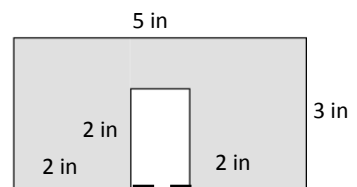
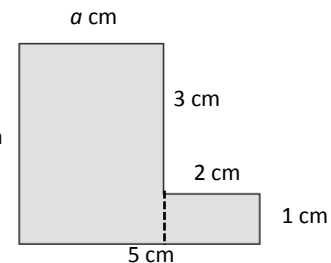

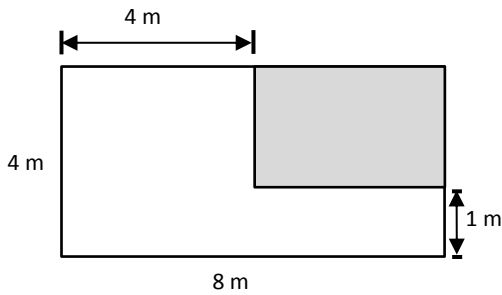

Students might find the perimeter of the shaded rectangle, the unshaded shape, and/or the large rectangle.

Problem Set (10 minutes)

Students should do their personal best to complete the Problem Set within the allotted 10 minutes. For some classes, it may be appropriate to modify the assignment by specifying which problems they work on first. Some problems do not specify a method for solving. Students solve these problems using the RDW approach used for Application Problems.

Student Debrief (10 minutes)

Lesson Objective: Use all four operations to solve problems involving perimeter and missing measurements.

The Student Debrief is intended to invite reflection and active processing of the total lesson experience.

Invite students to review their solutions for the Problem Set. They should check work by comparing answers with a partner before going over answers as a class. Look for misconceptions or misunderstandings that can be addressed in the Debrief. Guide students in a conversation to debrief the Problem Set and process the lesson.

You may choose to use any combination of the questions below to lead the discussion.

- Compare strategies for finding the missing side lengths in Problem 1.
- How was finding the missing side lengths in Problem 1(b) different from finding the missing side lengths in the rest of the shapes in Problem 1?
- Do the sizes of the shapes in Problem 1 accurately reflect the given units for each side length? Why or why not?
- Explain to your partner how you solved Problem 2. What strategy did you use to find the missing side lengths? What strategy did you use to add the side lengths?

- What is the perimeter of the unshaded shape in Problem 3? The large rectangle?
- What attribute about rectangles helped you find the perimeters of the shapes today?

Exit Ticket (3 minutes)

After the Student Debrief, instruct students to complete the Exit Ticket. A review of their work will help you assess the students' understanding of the concepts that were presented in the lesson today and plan more effectively for future lessons. You may read the questions aloud to the students.

NYS COMMON CORE MATHEMATICS CURRICULUM Lesson 17 Problem Set 3•7

2. Nathan draws and labels the square and rectangle below. Find the perimeter of the new shape.

$$P = (4 \times 6 \text{ cm}) + 12 \text{ cm} + 12 \text{ cm}$$

$$= 24 \text{ cm} + 24 \text{ cm}$$

$$= 48 \text{ cm}$$

The perimeter of the shape is 48 cm.

3. Label the missing side lengths. Then find the perimeter of the shaded rectangle.

$$P = 8 \text{ in} + 8 \text{ in} + 5 \text{ in} + 5 \text{ in}$$

$$= 16 \text{ in} + 10 \text{ in}$$

$$= 26 \text{ in}$$

The perimeter of the shaded rectangle is 26 inches.

COMMON CORE Lesson 17: Use all 4 operations to solve problems involving perimeter and missing measurements. Date: 11/20/13 engage^{ny} 7.C.8

© 2013 Common Core, Inc. Some rights reserved. commoncore.org

Name _____

Date _____

1. The shapes below are made up of rectangles. Label the missing side lengths. Then write and solve an equation to find the perimeter of each shape.

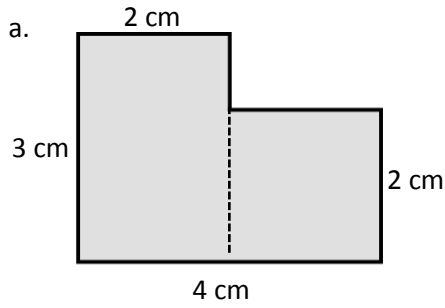

P =

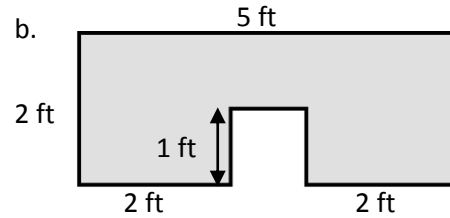

P =

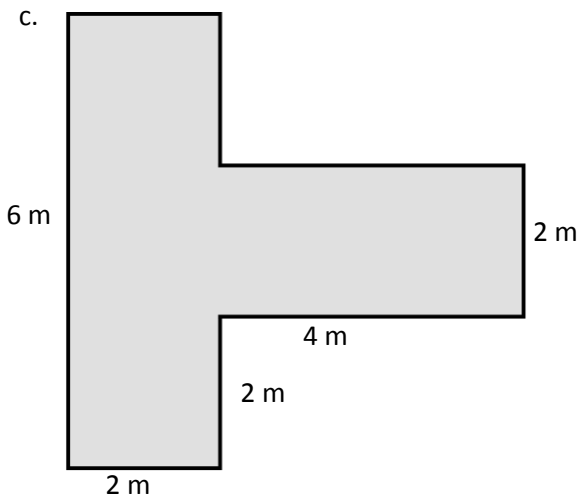

P =

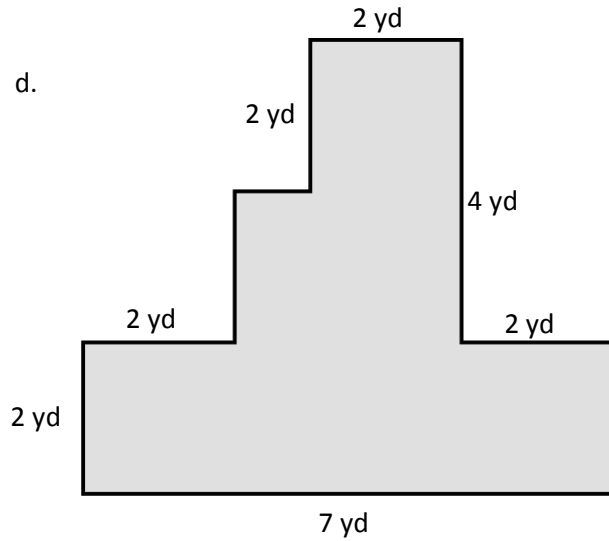

P =

2. Nathan draws and labels the square and rectangle below. Find the perimeter of the new shape.

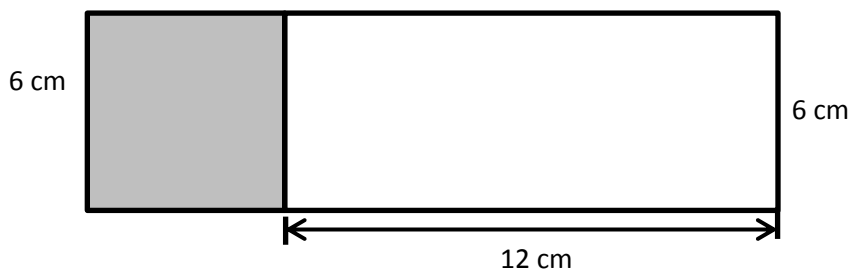

3. Label the missing side lengths. Then find the perimeter of the shaded rectangle.

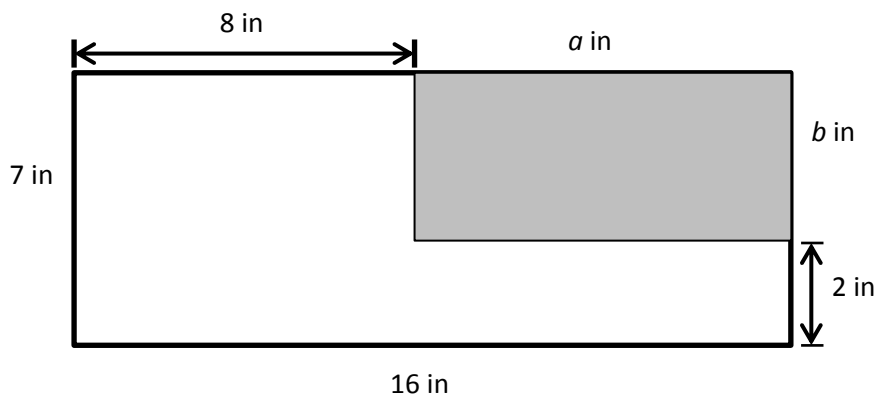

Name _____

Date _____

Label the missing side lengths. Then find the perimeter of the shaded rectangle.

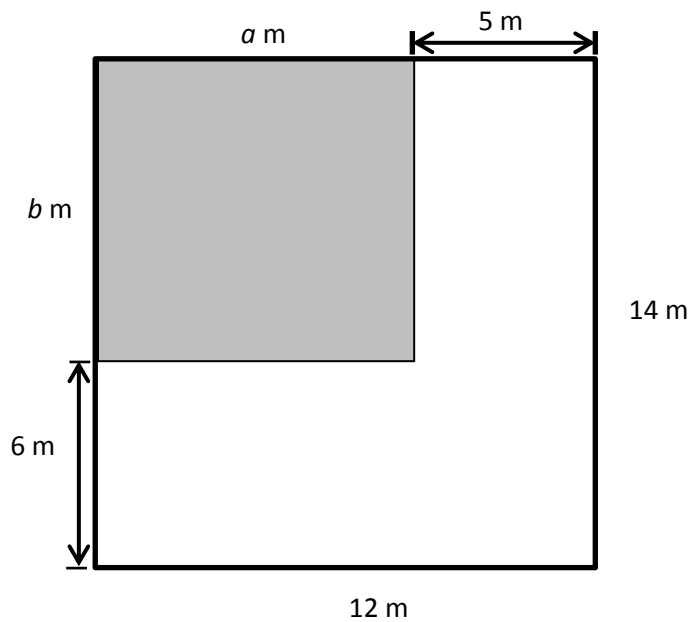

Name _____

Date _____

1. The shapes below are made up of rectangles. Label the missing side lengths. Then write and solve an equation to find the perimeter of each shape.

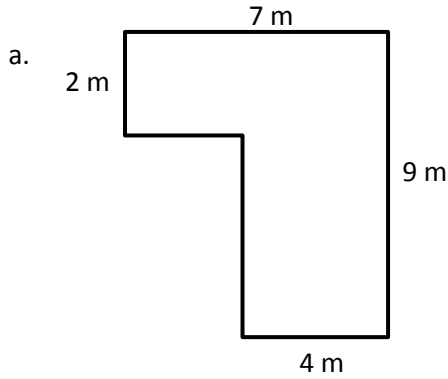

P =

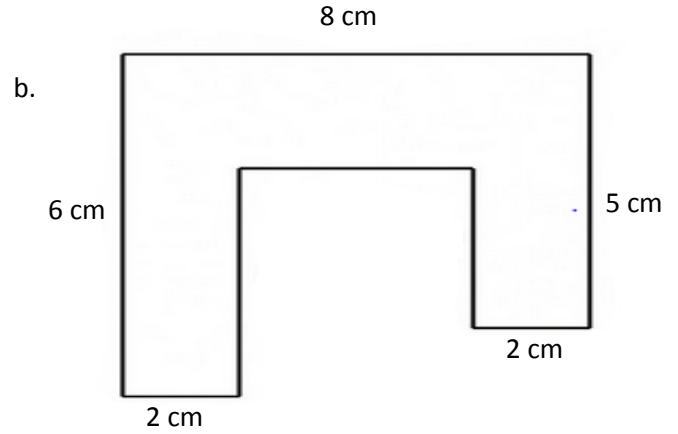

P =

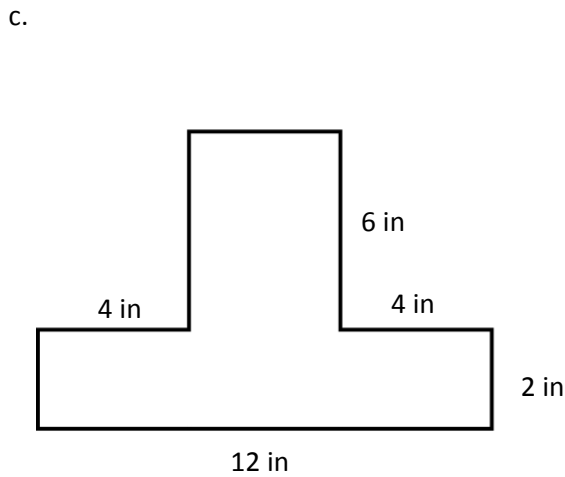

P =

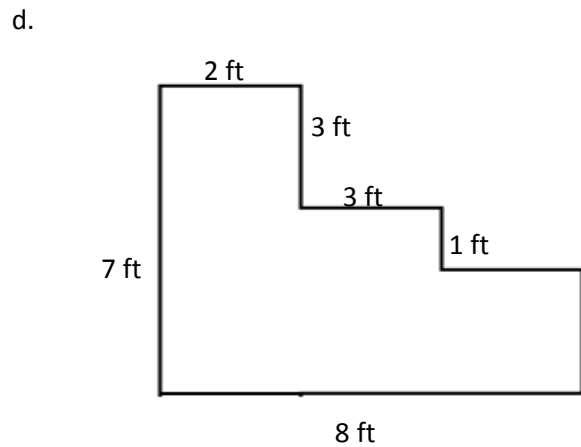

P =

2. Sari draws and labels the square and rectangle below. Find the perimeter of the new shape.

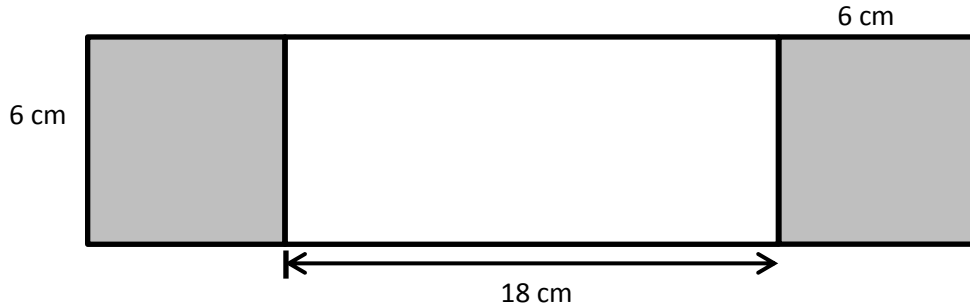

3. Label the missing side lengths. Then find the perimeter of the shaded rectangle.

