

NAME _____

DATE _____

PERIOD _____

Unit 7, Lesson 1: Relationships of Angles

Let's examine some special angles.

1.1: Visualizing Angles

m.openup.org/1/7-7-1-1



1. Which angle is bigger?

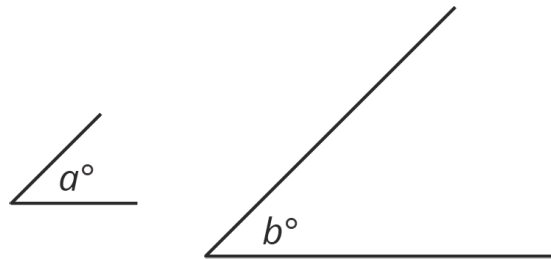

2. Identify an obtuse angle in the diagram.

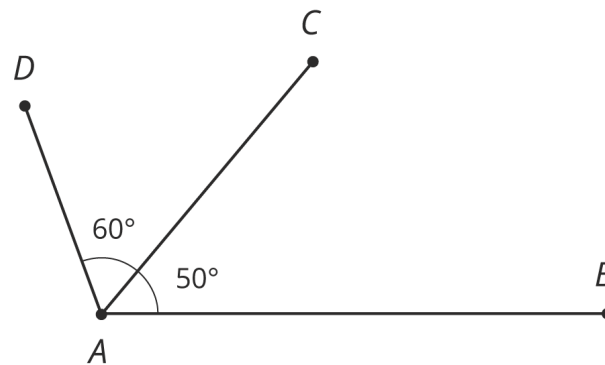

1.2: Pattern Block Angles

m.openup.org/1/7-7-1-2



1. Trace one copy of every different pattern block. Each block contains either 1 or 2 angles with different degree measures. Which blocks have only 1 unique angle? Which have 2?

NAME _____

DATE _____

PERIOD _____

2. If you trace three copies of the hexagon so that one vertex from each hexagon touches the same point, as shown, they fit together without any gaps or overlaps. Use this to figure out the degree measure of the angle inside the hexagon pattern block.

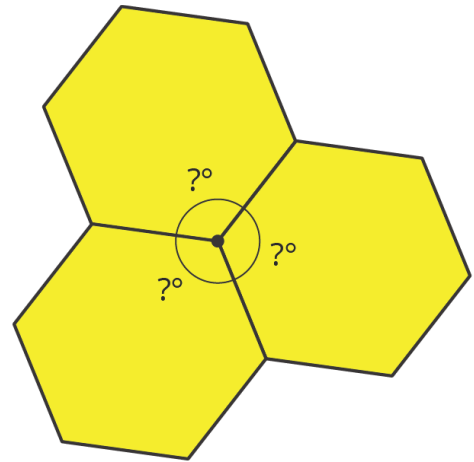

3. Figure out the degree measure of all of the other angles inside the pattern blocks that you traced in the first question. Be prepared to explain your reasoning.

Are you ready for more?

We saw that it is possible to fit three copies of a regular hexagon snugly around a point.

Each interior angle of a regular pentagon measures 108° .
Is it possible to fit copies of a regular pentagon snugly around a point? If yes, how many copies does it take? If not, why not?

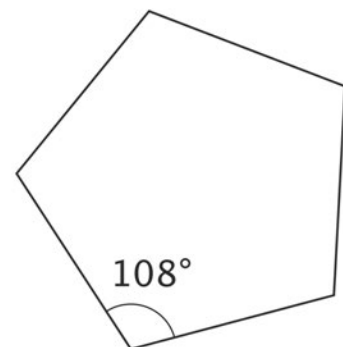

1.3: More Pattern Block Angles

1. Use pattern blocks to determine the measure of each of these angles.

m.openup.org/1/7-7-1-3



NAME

DATE

PERIOD

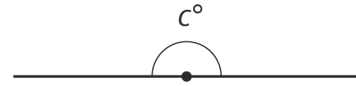
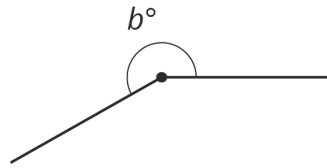
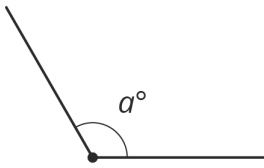

2. If an angle has a measure of 180° , then its sides form a straight line. An angle that forms a straight line is called a straight angle. Find as many different combinations of pattern blocks as you can that make a straight angle.

NAME _____

DATE _____

PERIOD _____

1.4: Measuring Like This or That

Tyler and Priya were both measuring angle TUS .

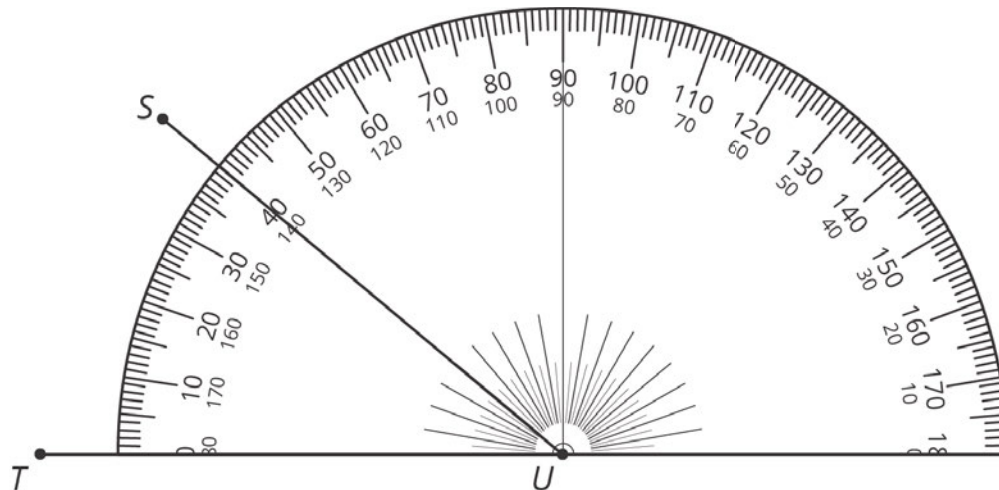

Priya thinks the angle measures 40 degrees. Tyler thinks the angle measures 140 degrees. Do you agree with either of them? Explain your reasoning.

NAME _____

DATE _____

PERIOD _____

Lesson 1 Summary

When two lines intersect and form four equal angles, we call each one a **right angle**. A right angle measures 90° . You can think of a right angle as a quarter turn in one direction or the other.

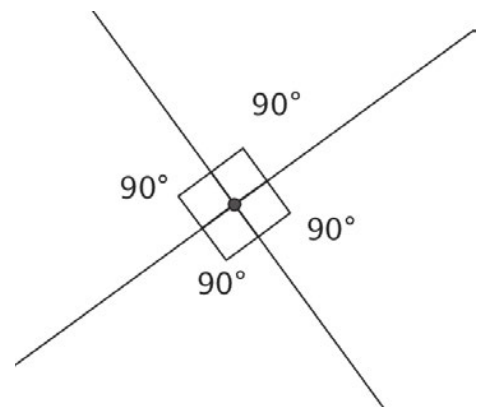

An angle in which the two sides form a straight line is called a **straight angle**. A straight angle measures 180° . A straight angle can be made by putting right angles together. You can think of a straight angle as a half turn, so that you are facing in the opposite direction after you are done.

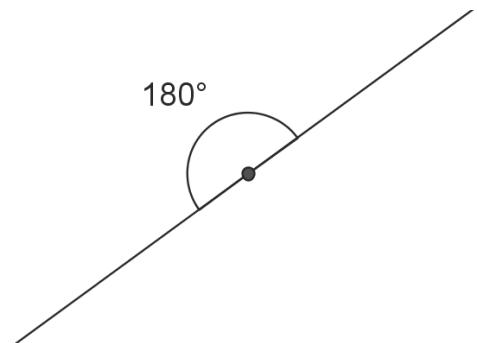

If you put two straight angles together, you get an angle that is 360° . You can think of this angle as turning all the way around so that you are facing the same direction as when you started the turn.

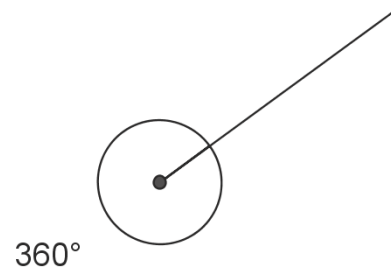

When two angles share a side and a vertex, and they don't overlap, we call them **adjacent angles**.

Lesson 1 Glossary Terms

- adjacent angles
- straight angle
- right angle

NAME

DATE

PERIOD

Unit 7, Lesson 1: Relationships of Angles

1. Here are questions about two types of angles.

Draw a right angle. How do you know it's a right angle? What is its measure in degrees?

Draw a straight angle. How do you know it's a straight angle? What is its measure in degrees?

2. An equilateral triangle's angles each have a measure of 60 degrees.

a. Can you put copies of an equilateral triangle together to form a straight angle? Explain or show your reasoning.

b. Can you put copies of an equilateral triangle together to form a right angle? Explain or show your reasoning.

3. Here is a square and some regular octagons.

NAME _____

DATE _____

PERIOD _____

In this pattern, all of the angles inside the octagons have the same measure. The shape in the center is a square. Find the measure of one of the angles inside one of the octagons.

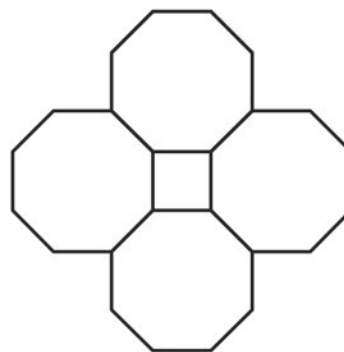

4. The height of the water in a tank decreases by 3.5 cm each day. When the tank is full, the water is 10 m deep. The water tank needs to be refilled when the water height drops below 4 m.

a. Write a question that could be answered by solving the equation $10 - 0.035d = 4$.

b. Is 100 a solution of $10 - 0.035d > 4$? Write a question that solving this problem could answer.

(from Unit 6, Lesson 17)

5. Use the distributive property to write an expression that is equivalent to each given expression.

a. $-3(2x - 4)$

b. $0.1(-90 + 50a)$

c. $-7(-x - 9)$

d. $\frac{4}{5}(10y + -x + -15)$

NAME

DATE

PERIOD

(from Unit 6, Lesson 18)

6. Lin's puppy is gaining weight at a rate of 0.125 pounds per day. Describe the weight gain in days per pound.

(from Unit 2, Lesson 3)