

NAME \_\_\_\_\_

DATE \_\_\_\_\_

PERIOD \_\_\_\_\_

# Unit 1, Lesson 4: Scaled Relationships

Let's find relationships between scaled copies.

## 4.1: Three Quadrilaterals (Part 1)

Each of these polygons is a scaled copy of the others.

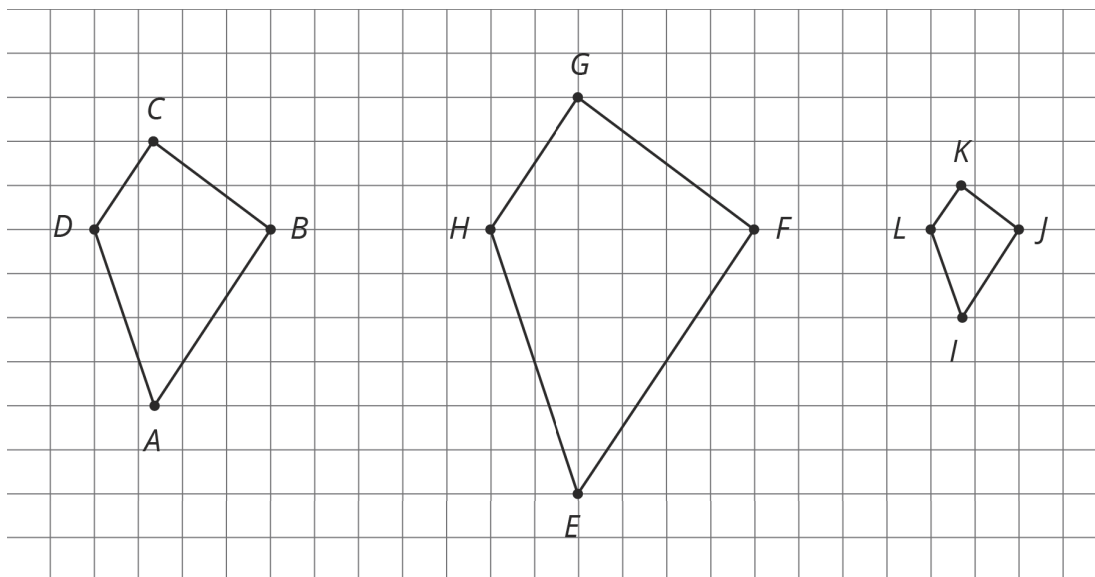

1. Name two pairs of corresponding angles. What can you say about the sizes of these angles?
  
2. Check your prediction by measuring at least one pair of corresponding angles using a protractor. Record your measurements to the nearest  $5^\circ$ .

NAME \_\_\_\_\_

DATE \_\_\_\_\_

PERIOD \_\_\_\_\_

### 4.2: Three Quadrilaterals (Part 2)

Each of these polygons is a scaled copy of the others. You already checked their corresponding angles.

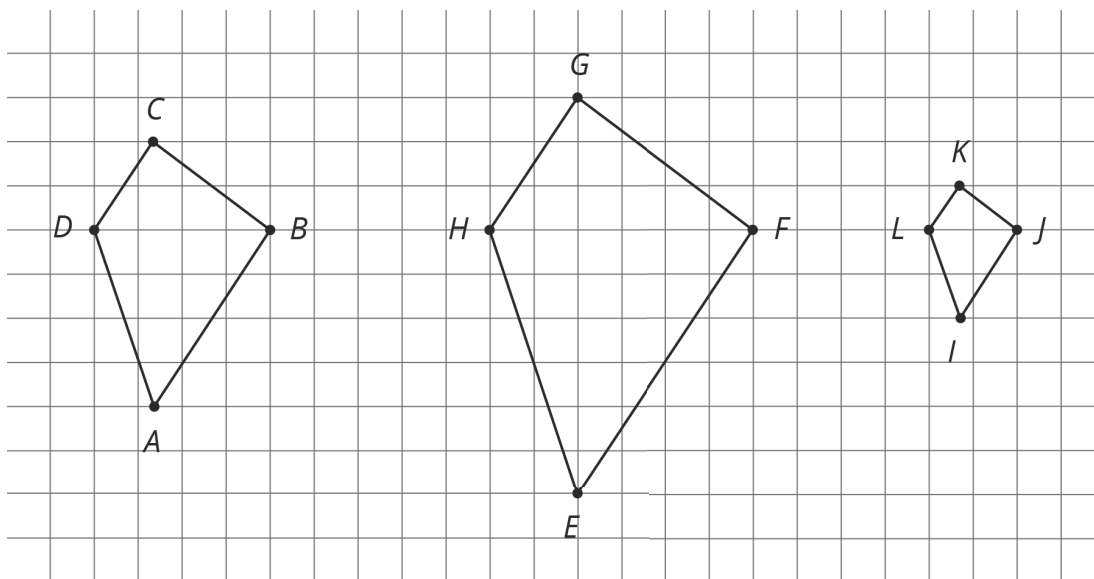

- The side lengths of the polygons are hard to tell from the grid, but there are other *corresponding distances* that are easier to compare. Identify the distances in the other two polygons that correspond to  $DB$  and  $AC$ , and record them in the table.

quadrilateral	distance that corresponds to $DB$	distance that corresponds to $AC$
$ABCD$	$DB = 4$	$AC = 6$
$EFGH$		
$IJKL$		

- Look at the values in the table. What do you notice?

Pause here so your teacher can review your work.

NAME \_\_\_\_\_

DATE \_\_\_\_\_

PERIOD \_\_\_\_\_

3. The larger figure is a scaled copy of the smaller figure.

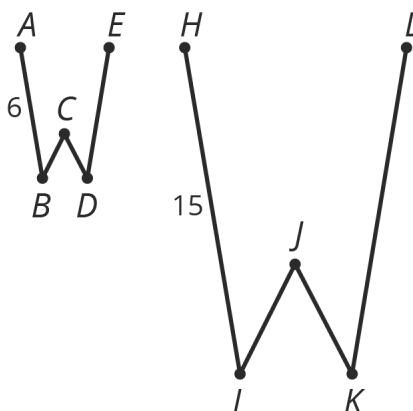

- If  $AE = 4$ , how long is the corresponding distance in the second figure? Explain or show your reasoning.
- If  $IK = 5$ , how long is the corresponding distance in the first figure? Explain or show your reasoning.

### 4.3: Scaled or Not Scaled?

Here are two quadrilaterals.

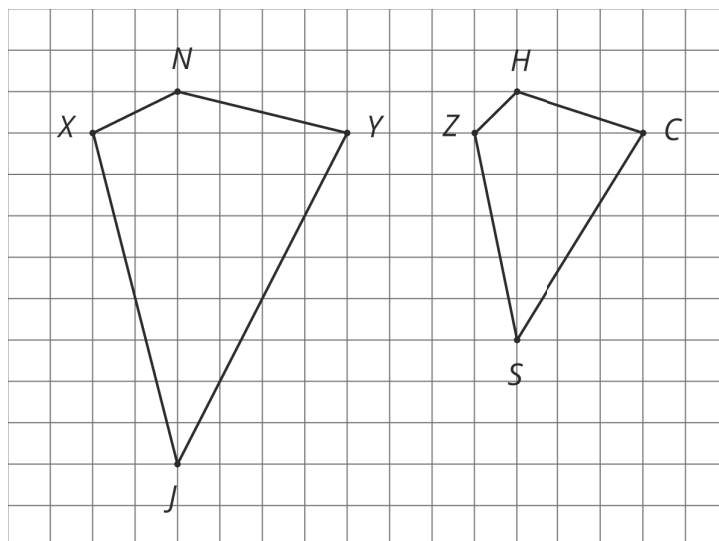

---

NAME

DATE

PERIOD

1. Mai says that Polygon  $ZSCH$  is a scaled copy of Polygon  $XJYN$ , but Noah disagrees. Do you agree with either of them? Explain or show your reasoning.

NAME \_\_\_\_\_

DATE \_\_\_\_\_

PERIOD \_\_\_\_\_

2. Record the corresponding distances in the table. What do you notice?

quadrilateral	horizontal distance	vertical distance
<i>XJYN</i>	$XY =$	$JN =$
<i>ZSCH</i>	$ZC =$	$SH =$

3. Measure at least three pairs of corresponding angles in *XJYN* and *ZSCH* using a protractor. Record your measurements to the nearest  $5^\circ$ . What do you notice?

4. Do these results change your answer to the first question? Explain.

Here are two more quadrilaterals.

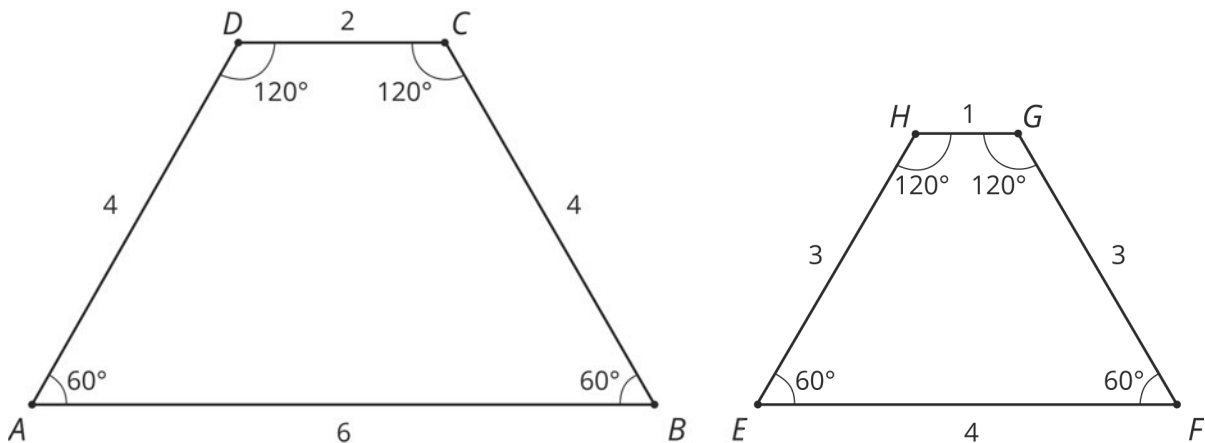

5. Kiran says that Polygon *EFGH* is a scaled copy of *ABCD*, but Lin disagrees. Do you agree with either of them? Explain or show your reasoning.

NAME

DATE

PERIOD

**Are you ready for more?**

All side lengths of quadrilateral  $MNOP$  are 2, and all side lengths of quadrilateral  $QRST$  are 3. Does  $MNOP$  have to be a scaled copy of  $QRST$ ? Explain your reasoning.

**4.4: Comparing Pictures of Birds**[m.openup.org/1/7-1-4-4](https://m.openup.org/1/7-1-4-4)

Here are two pictures of a bird. Find evidence that one picture is not a scaled copy of the other. Be prepared to explain your reasoning.

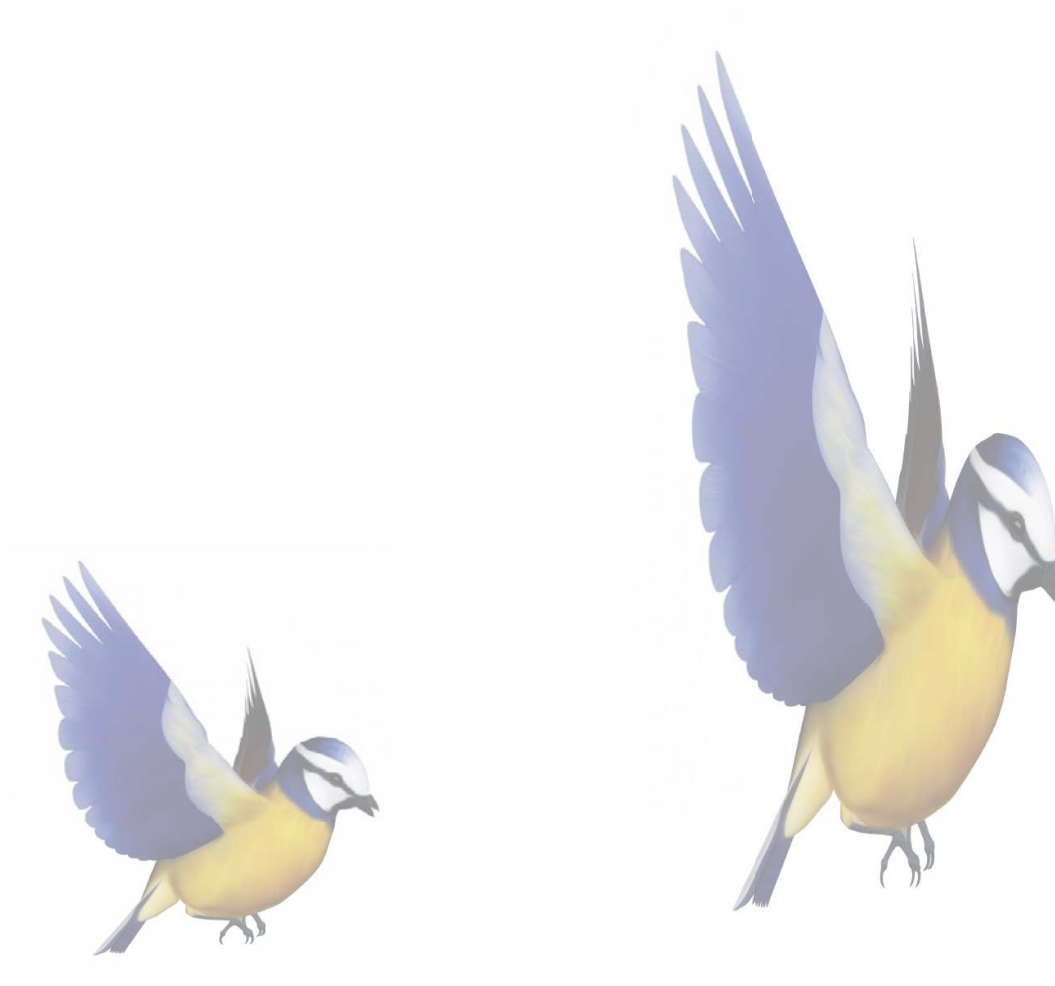

NAME \_\_\_\_\_

DATE \_\_\_\_\_

PERIOD \_\_\_\_\_

## Lesson 4 Summary

When a figure is a scaled copy of another figure, we know that:

1. All distances in the copy can be found by multiplying the *corresponding distances* in the original figure by the same scale factor, whether or not the endpoints are connected by a segment.

For example, Polygon  $STUVWX$  is a scaled copy of Polygon  $ABCDEF$ . The scale factor is 3. The distance from  $T$  to  $X$  is 6, which is three times the distance from  $B$  to  $F$ .

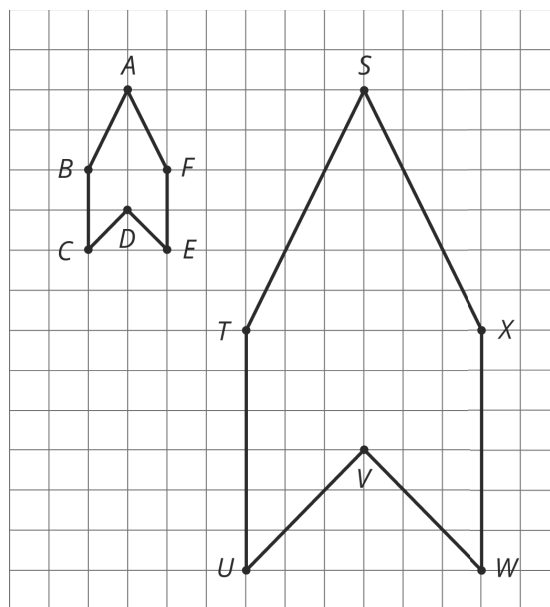

2. All angles in the copy have the same measure as the corresponding angles in the original figure, as in these triangles.

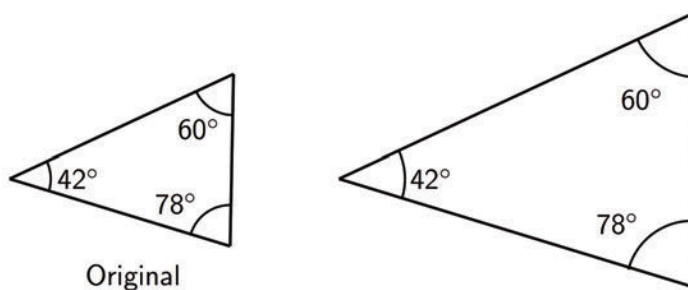

These observations can help explain why one figure is *not* a scaled copy of another.

For example, even though their corresponding angles have the same measure, the second rectangle is not a scaled copy of the first rectangle, because different pairs of corresponding lengths have different scale factors,  $2 \cdot \frac{1}{2} = 1$  but  $3 \cdot \frac{2}{3} = 2$ .



NAME \_\_\_\_\_

DATE \_\_\_\_\_

PERIOD \_\_\_\_\_

## Unit 1, Lesson 4: Scaled Relationships

1. Select **all** the statements that must be true for *any* scaled copy Q of Polygon P.

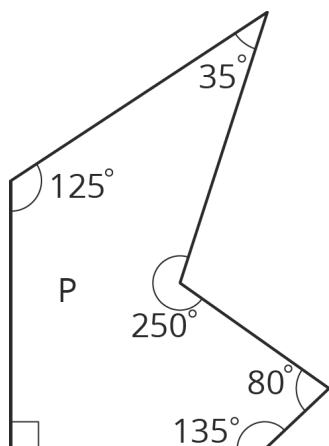

- A. The side lengths are all whole numbers.
- B. The angle measures are all whole numbers.
- C. Q has exactly 1 right angle.
- D. If the scale factor between P and Q is  $\frac{1}{5}$ , then each side length of P is multiplied by  $\frac{1}{5}$  to get the corresponding side length of Q.
- E. If the scale factor is 2, each angle in P is multiplied by 2 to get the corresponding angle in Q.
- F. Q has 2 acute angles and 3 obtuse angles.

2. Here is Quadrilateral  $ABCD$ .

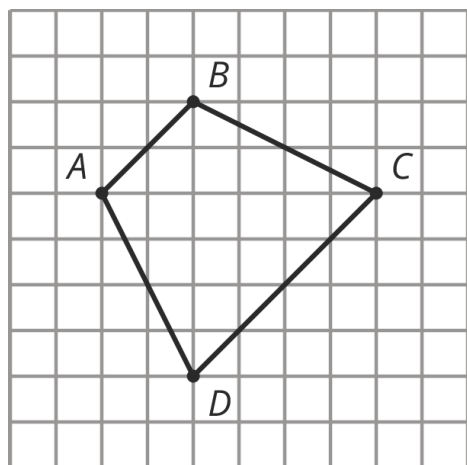

Quadrilateral  $PQRS$  is a scaled copy of Quadrilateral  $ABCD$ . Point  $P$  corresponds to  $A$ ,  $Q$  to  $B$ ,  $R$  to  $C$ , and  $S$  to  $D$ .

If the distance from  $P$  to  $R$  is 3 units, what is the distance from  $Q$  to  $S$ ? Explain your reasoning.

3. Figure 2 is a scaled copy of Figure 1.



NAME \_\_\_\_\_

DATE \_\_\_\_\_

PERIOD \_\_\_\_\_

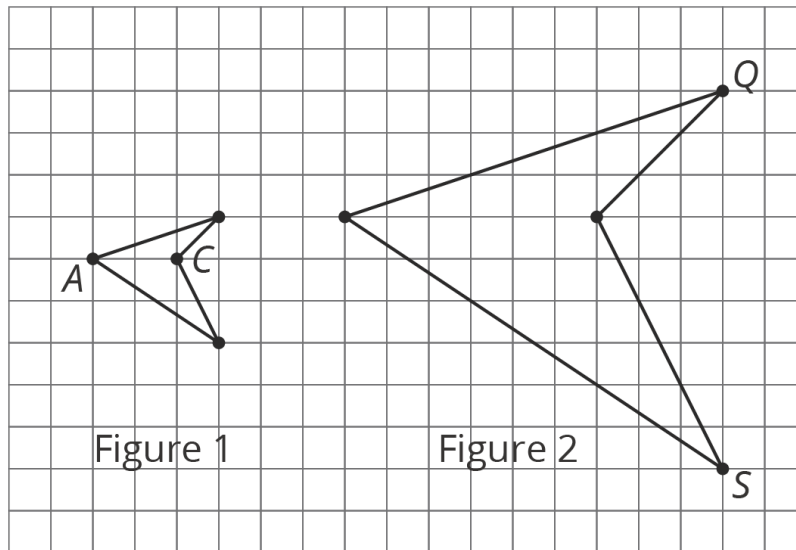

- Identify the points in Figure 2 that correspond to the points  $A$  and  $C$  in Figure 1. Label them  $P$  and  $R$ . What is the distance between  $P$  and  $R$ ?
  - Identify the points in Figure 1 that correspond to the points  $Q$  and  $S$  in Figure 2. Label them  $B$  and  $D$ . What is the distance between  $B$  and  $D$ ?
  - What is the scale factor that takes Figure 1 to Figure 2?
  - $G$  and  $H$  are two points on Figure 1, but they are not shown. The distance between  $G$  and  $H$  is 1. What is the distance between the corresponding points on Figure 2?
4. To make 1 batch of lavender paint, the ratio of cups of pink paint to cups of blue paint is 6 to 5. Find two more ratios of cups of pink paint to cups of blue paint that are equivalent to this ratio.

(from Grade 7, Unit 2, Lesson 4)