

NAME _____

DATE _____

PERIOD _____

Unit 2, Lesson 8: How Much for One?

Let's use ratios to describe how much things cost.

8.1: Number Talk: Remainders in Division

Find the quotient mentally.

$$246 \div 12$$

8.2: Grocery Shopping

m.openup.org/1/6-2-8-2



Answer each question and explain or show your reasoning. If you get stuck, consider drawing a double number line diagram.

1. Eight avocados cost \$4.

- How much do 16 avocados cost?
- How much do 20 avocados cost?
- How much do 9 avocados cost?



2. Twelve large bottles of water cost \$9.

- How many bottles can you buy for \$3?
- What is the cost per bottle of water?
- How much would 7 bottles of water cost?



3. A 10-pound sack of flour costs \$8.

- How much does 40 pounds of flour cost?
- What is the cost per pound of flour?

NAME

DATE

PERIOD

Are you ready for more?

Is bigger always better? It is commonly thought that buying larger packages or containers, sometimes called *buying in bulk*, is a great way to save money. For example, a 6-pack of soda might cost \$3 while a 12-pack of the same brand costs \$5.

Find 3 different cases where it is not true that buying in bulk saves money. You may use the internet or go to a local grocery store and take photographs of the cases you find. Make sure the products are the same brand. For each example that you find, give the quantity or size of each, and describe how you know that the larger size is not a better deal.

8.3: More Shoppingm.openup.org/1/6-2-8-3

1. Four bags of chips cost \$6.
 - a. What is the cost per bag?
 - b. At this rate, how much will 7 bags of chips cost?
2. At a used book sale, 5 books cost \$15.
 - a. What is the cost per book?
 - b. At this rate, how many books can you buy for \$21?
3. Neon bracelets cost \$1 for 4.
 - a. What is the cost per bracelet?
 - b. At this rate, how much will 11 neon bracelets cost?



Pause here so you teacher can review your work.

4. Your teacher will assign you one of the problems. Create a visual display that shows your solution to the problem. Be prepared to share your solution with the class.

NAME _____

DATE _____

PERIOD _____

Lesson 8 Summary

The **unit price** is the price of 1 thing—for example, the price of 1 ticket, 1 slice of pizza, or 1 kilogram of peaches.

If 4 movie tickets cost \$28, then the unit price would be the cost *per* ticket. We can create a double number line to find the unit price.

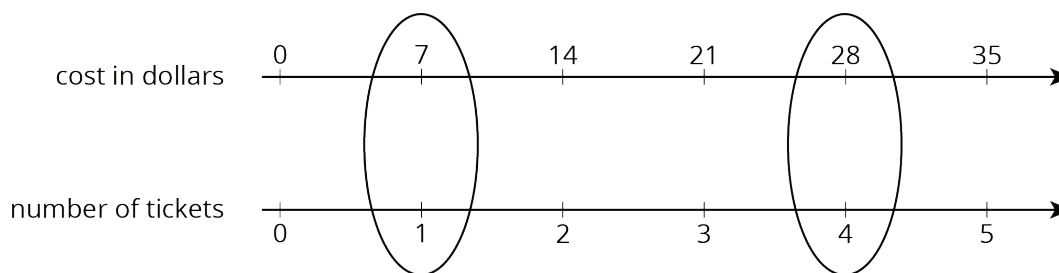

This double number line shows that the cost for 1 ticket is \$7. We can also find the unit price by dividing, $28 \div 4 = 7$, or by multiplying, $28 \cdot \frac{1}{4} = 7$.

Lesson 8 Glossary Terms

- unit price

NAME _____

DATE _____

PERIOD _____

Unit 2, Lesson 8: How Much for One?

1. In 2016, the cost of 2 ounces of pure gold was \$2,640. Complete the double number line to show the cost for 1, 3, and 4 ounces of gold.

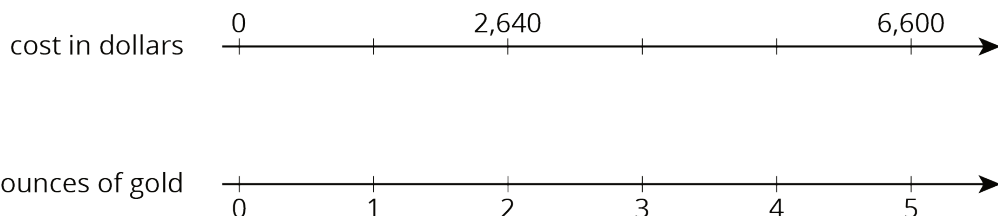

2. The double number line shows that 4 pounds of tomatoes cost \$14. Draw tick marks and write labels to show the prices of 1, 2, and 3 pounds of tomatoes.

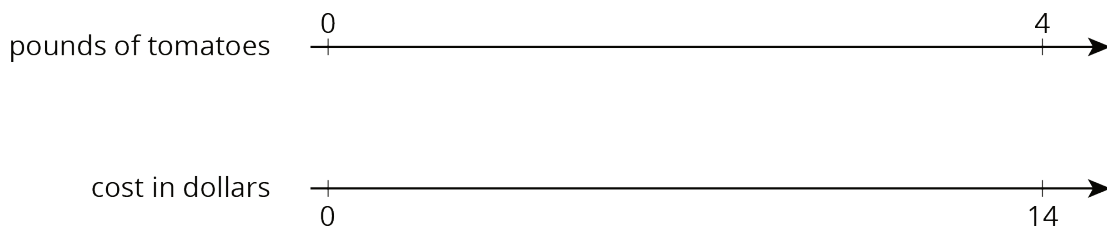

3. 4 movie tickets cost \$48. At this rate, what is the cost of:

- a. 5 movie tickets?
- b. 11 movie tickets?

4. Priya bought these items at the grocery store. Find each unit price.

- a. 12 eggs for \$3. How much is the cost per egg?
- b. 3 pounds of peanuts for \$7.50. How much is the cost per pound?
- c. 4 rolls of toilet paper for \$2. How much is the cost per roll?
- d. 10 apples for \$3.50. How much is the cost per apple?

5. Clare made a smoothie with 1 cup of yogurt, 3 tablespoons of peanut butter, 2 teaspoons of chocolate syrup, and 2 cups of crushed ice.

NAME

DATE

PERIOD

a. Kiran tried to double this recipe. He used 2 cups of yogurt, 6 tablespoons of peanut butter, 5 teaspoons of chocolate syrup, and 4 cups of crushed ice. He didn't think it tasted right. Describe how the flavor of Kiran's recipe compares to Clare's recipe.

b. How should Kiran change the quantities that he used so that his smoothie tastes just like Clare's?

(from Unit 2, Lesson 3)

6. A drama club is building a wooden stage in the shape of a trapezoidal prism. The height of the stage is 2 feet. Some measurements of the stage are shown here.

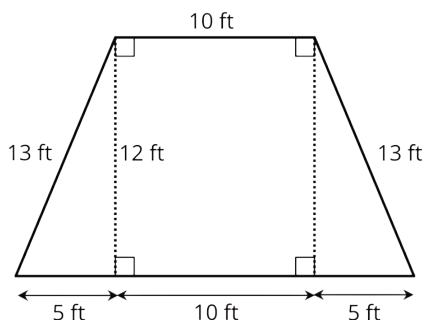
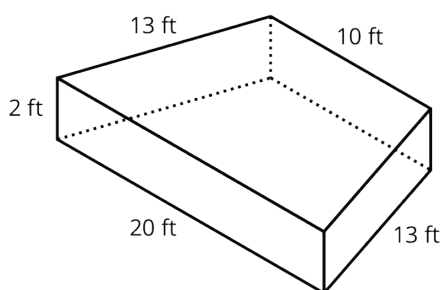

What is the area of all the faces of the stage, excluding the bottom? Show your reasoning. If you get stuck, consider drawing a net of the prism.

(from Unit 1, Lesson 15)